

# PLATE LOADED



Olympic weight plates & spring collars not included.

## HACK SQUAT



PPL-965

- Dual self-aligning 1-1/2" linear bearing system.
- 1-1/2" precision ground tempered solid steel shafts.
- Oversized convex footplate design assures correct ankle and knee positioning throughout full range of motion.
- Dual safety catch and release handles.
- 35° angle of travel
- Custom convex press plate design with calf block and bi-level weight holders (starting weight 95 lbs).
- Built-in Olympic weight storage.
- 14-1/2" weight horn and 7-1/2" top weight horn.

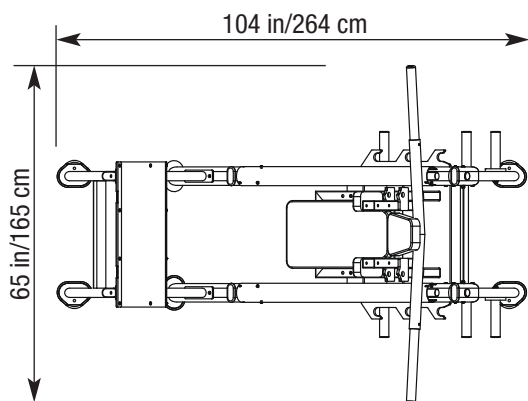

Ht: 58 in/147 cm Wt: 520 lb/236 kg

## LEG PRESS



PPL-960

- Dual self-aligning 1-1/2" linear bearing system.
- 1-1/2" precision ground tempered solid steel shafts.
- Oversized convex footplate design assures correct ankle and knee positioning throughout full range of motion.
- Dual safety catch and release handles.
- Heavy duty back support with multiple angle adjustments.
- Custom convex press plate design with calf block and bi-level weight holders (starting weight 95 lbs).
- Built-in Olympic weight storage.
- 14-1/2" weight horn and 7-1/2" top weight horn.

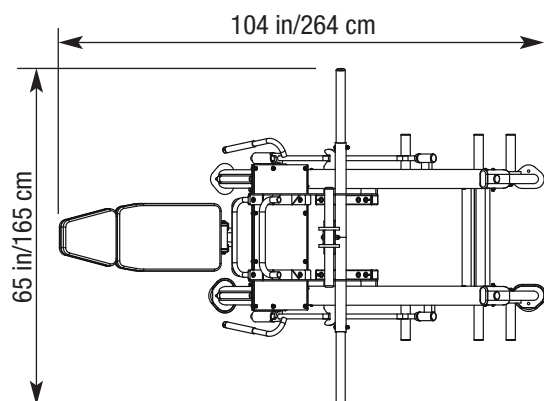

Ht: 58 in/147 cm Wt: 555 lb/252 kg